

公司简介

泉州市肯能自动化机械有限公司是一家集研发、生产、销售和技术服务于一体化的智能化包装机械制造商，公司汇聚了一批有着多年生活用纸机械及包装机械行业研发设计经验的专业人才，专注于生活用纸行业的自动化包装技术，致力为客户打造高效自动化工厂。

公司主要产品有婴儿纸尿裤包装线、拉拉裤包装线、成人尿裤包装线、卫生巾包装线、自动装盒机、机械手、工厂自动化软件等高端技术产品。

COMPANY PROFILE

Quanzhou CAM Machinery Co., Ltd is an intelligent packing machine manufacturer, focus on research and develop, manufacturing, sales and service. Our professional technician have plentiful experience in household paper machine and packing machine research and design. Concentrate on household paper automatic packing technology to help every costumers build up high efficiency production plant.

Main products including baby diaper packing line, training pants packing line , adult diaper packing line, sanitary napkins packing line, box packing machine, mechanical hand and factory automatic software etc. Our products.



赖 纯阳 | +86-158 8098 7848
销售经理



泉州市肯能自动化机械有限公司

地址: 福建省泉州市石狮鸿山镇东园村工业区
电话: +86-595-83127255 传真: +86-595-83127355
邮箱: Lai@cam-machinery.com 服务热线: 400 012 8015
网址: www.cam-machinery.com

Daniel Lai Sales Manager
Mobile: +86-158 8098 7848



Quanzhou CAM Machinery Co., Ltd.

Add: Shishi Hongshan Town Dongyuan Industrial Zone,
Quanzhou, Fujian, China
Tel: +86-595-83127255 Fax: +86-595-83127355
E-mail: Lai@cam-machinery.com Service hotline: 400 012 8015
Http://www.cam-machinery.com

CAM-103A

婴儿纸尿裤包装机 (欧式袋) Packaging of baby diapers (Bottom insertion angle)



Features 产品特点

- 全伺服运动控制系统，通过电子轴进行的伺服电机管理
- Fully servo driven, Servo motor management by electronic CAM
- 二次压缩，适合大压缩量规格包装
- Two levels compression, suitable for varied size of packing
- 模块化结构设计
- Modular structure design
- 采用伺服电机或计数器显示规格调整，快速更换规格
- Quick Auto/ Manual packing size switching
- 力矩限制保护，机械性能更稳定
- Force restrict protection, stable running
- 垛堆包装一体化设计，占用空间小
- Stacking and packing 2 in 1, less land occupied
- 适应单排或双排包装
- Suitable for single row or double rows packing



Main technical data 主要技术参数

Working speed 生产速度	Up to 450-550 pieces/min and 20-30 bags/min 接片速度450-550片/分，包装速度20-30包/分钟
Finished product rate 成品率	≥ 98%
Product thickness dimensions 产品厚度尺寸	8-16mm
Number of products per row 单排片数	10-45pieces/row 10-45片/排
Finished bags dimensions, single row W x H x L	Min. 120x100x120 mm Max. 480x140x280 mm
单排包装尺寸: W x H x L	Min. 120x100x120 mm Max. 480x140x280 mm
Finished bags dimension, double rows W x H x L	Min. 120x100x280 mm Max. 480x140x560 mm
双排包装尺寸: W x H x L	Min. 120x100x280 mm Max. 480x140x560 mm
Pre-made bags dimensions: W x L	Min. 220x220 mm Max. 580x650 mm
预制袋尺寸: W x L	Min. 220x220 mm Max. 580x650 mm
Pre-made bags (PE) thickness 预制袋膜(PE)厚度:	40-80μ m 40-80μ m
General dimensions (LxWxH)	5400x4100x2100 mm 8200x4100x2100 mm (including material receiver)
机台外观尺寸 (LxWxH)	5400x4100x2100 mm 8200x4100x2100 mm (含接料机)
Weight 重量	5500KG
Electrical Power consumption 功率	25KVA (20Kw) 25KVA
Air Supply 供气压力	0.65-0.85Mpa 0.65-0.85Mpa
Standard process direction 标准生产流程方向	Left-hand process. Right-hand process direction available upon request 左手方向，右手方向可定制

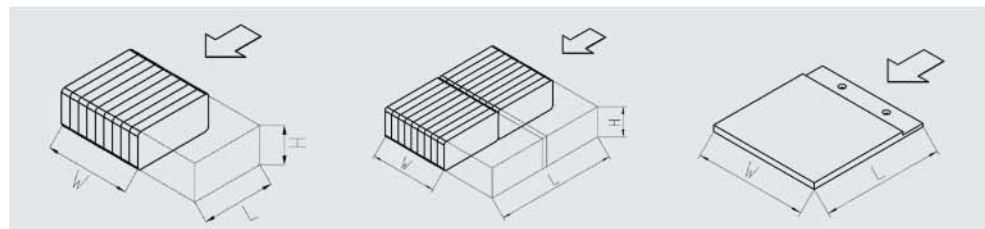

CAM-102B

婴儿纸尿裤包装机 (中式袋) Packaging of baby diapers (Side insertion angle)



Features 产品特点

- 全伺服运动控制系统，通过电子轴进行的伺服电机管理
- Fully servo driven, Servo motor management by electronic CAM
- 二次压缩，适合大压缩量规格包装
- Two levels compression, suitable for varied size of packing
- 模块化结构设计
- Modular structure design
- 采用伺服电机或计数器显示规格调整，快速更换规格
- Quick Auto/ Manual packing size switching
- 力矩限制保护，机械性能更稳定
- Force restrict protection, stable running
- 垛堆包装一体化设计，占用空间小
- Stacking and packing 2 in 1, less land occupied
- 适应单排或双排包装
- Suitable for single row or double rows packing



Main technical data 主要技术参数

Working speed	Up to 450-550 pieces/min and 20-30 bags/min
生产速度	接片速度450-550片/分，包装速度20-30包/分钟
Finished product rate	≥ 98%
成品率	≥ 98%
Product thickness dimensions	8-16mm
产品厚度尺寸	8-16mm
Number of pieces per row	16-45pieces/row
单排片数	16-45片/排
Finished bags dimensions, single row W x H x L	Min. 200x100x140 mm Max. 420x140x280 mm
单排包装尺寸: W x H x L	Min. 200x100x140 mm Max. 420x140x280 mm
Finished bags dimension, double rows W x H x L	Min. 200x100x280 mm Max. 420x140x560 mm
双排包装尺寸: W x H x L	Min. 200x100x280 mm Max. 420x140x560 mm
Pre-made bags dimensions: W x L	Min. 200x300 mm Max. 420x680 mm
预制袋尺寸: W x L	Min. 200x300 mm Max. 420x680 mm
Pre-made bags (PE) thickness	40-80μ m
预制袋膜(PE)厚度	40-80μ m
General dimensions (LxWxH)	5400x3860x2100 mm 8200x3860x2100 mm (including material receiver)
机台外观尺寸 (LxWxH)	5400x3860x2100 mm 8200x3860x2100 mm (含接料机)
Weight	6000KG
重量	6000KG
Electrical Power consumption	25KVA
功率	25KVA
Air Supply	0.65-0.85Mpa
供气压力	0.65-0.85Mpa
Standard process direction	Left-hand process , Right-hand process direction available upon request
标准生产流程方向	左手方向，右手方向可定制

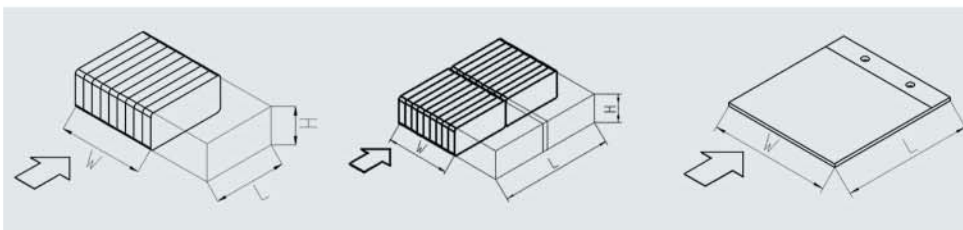

CAM-202A

婴儿拉拉裤、成人纸尿裤包装机（欧式袋） Packaging of training pants and pull-on diapers (Bottom insertion angle)



Features 产品特点

- 全伺服运动控制系统，通过电子轴进行的伺服电机管理
- Fully servo driven, Servo motor management by electronic CAM
- 模块化结构设计
- Modular structure design
- 采用伺服电机或计数器显示规格调整，快速更换规格
- Quick Auto/ Manual packing size switching
- 力矩限制保护，机械性能更稳定
- Force restrict protection, stable running
- 垛堆包装一体化设计，占用空间小
- Stacking and packing 2 in 1, less land occupied
- 适应单排或双排包装
- Suitable for single row or double rows packing



Main technical data 主要技术参数

Working speed	UP to 450-550 pieces/min and 20-30 bags/min
生产速度	接片速度450-550片/分, 包装速度20-30包/分钟
Finished product rate	≥ 98%
成品率	≥ 98%
Product thickness dimensions	8-16mm
产品厚度尺寸	8-16mm
Number of pieces per row	12-45pieces/row
单排片数	12-45片/排
Finished bags dimensions, single row W x H x L	Min. 140x100x120 mm Max. 450x220x300 mm
单排包装尺寸: W x H x L	Min. 140x100x120 mm Max. 450x220x300 mm
Pre-made bags dimensions: W x L	Min. 280x220 mm Max. 550x650 mm
预制袋尺寸: W x L	Min. 280x220 mm Max. 550x650 mm
Pre-made bags (PE) thickness	40-80μ m
预制袋膜(PE)厚度	40-80μ m
General dimensions (LxWxH)	4350x4100x2100 mm 7150x4100x2100 mm (including Material receiver)
机台外观尺寸 (LxWxH)	4350x4100x2100 mm 7150x4100x2100 mm (含接料机)
Weight	4200KG
重量	4200KG
Electrical Power consumption	25KVA
功率	25KVA
Air Supply	0.65-0.85Mpa
供气压力	0.65-0.85Mpa
Standard process direction	Left-hand process, Right-hand process direction available upon request
标准生产流程方向	左手方向, 右手方向可定制

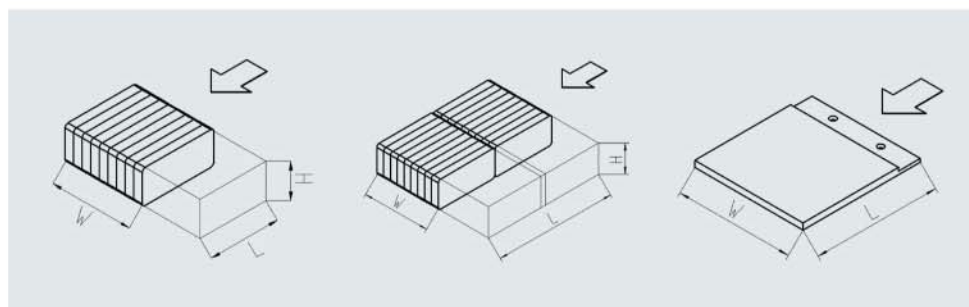

CAM-400

自动装盒机 Packaging of tissue box

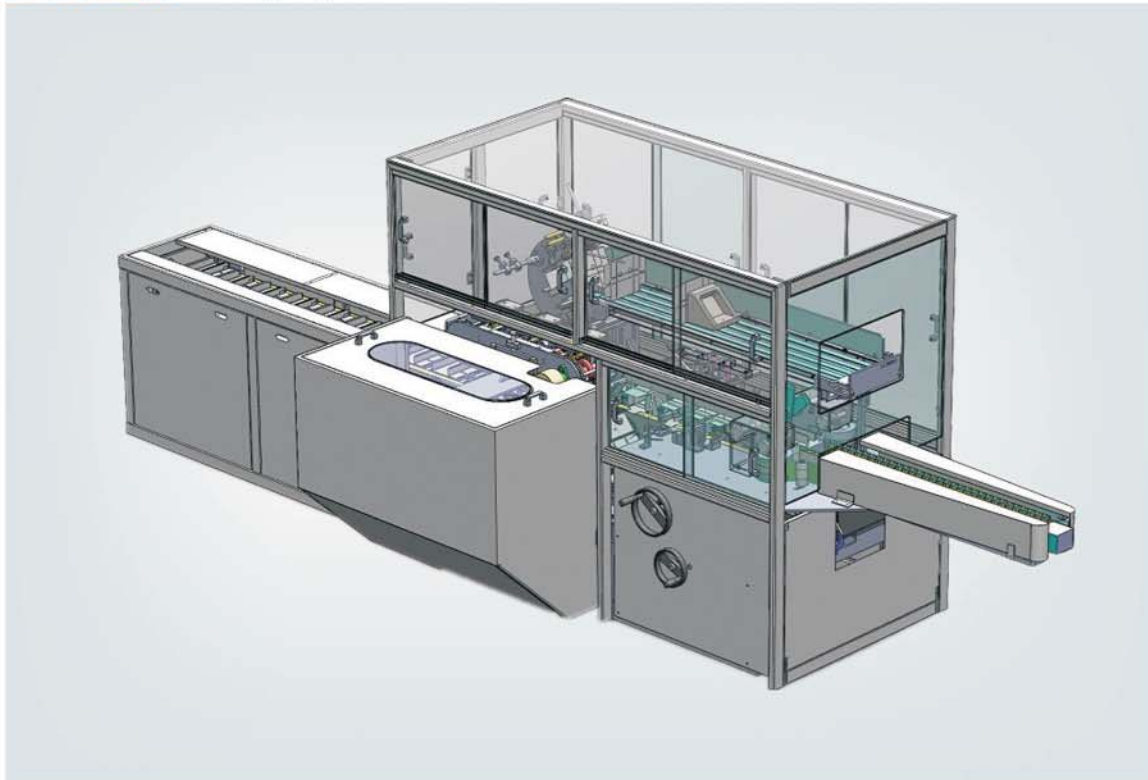

Main technical data 主要技术参数

Working speed	Up to 120 box/min
生产速度	包装速度120盒/分钟
Finished product rate	≥ 98%
成品率	≥ 98%
Finished bags dimensions: W x H x L	Min. 70x50x90 mm Max. 100x100x240 mm
包装尺寸: W x H x L	Min. 30x30x55 mm Max. 100x135x230 mm
General dimensions (LxWxH)	5000x1640x1720 mm
机台外观尺寸 (LxWxH)	5000X1640X1720 mm
Weight	2000KG
重量	2000KG
Electrical Power consumption	8KVA
功率	8KVA
Air Supply	0.65-0.85Mpa
供气压力	0.65-0.85Mpa

Features 产品特点

- 适用于卫生巾、护垫、纸巾的盒式包装，也可适用于牙膏、药瓶、食品等的盒式包装
- Cassette packaging suitable for use in lady sanitary napkins , paper towels , pad , toothpaste , medicine , food
- 连续式包装，包装效率高
- Continuous packaging , High efficiency

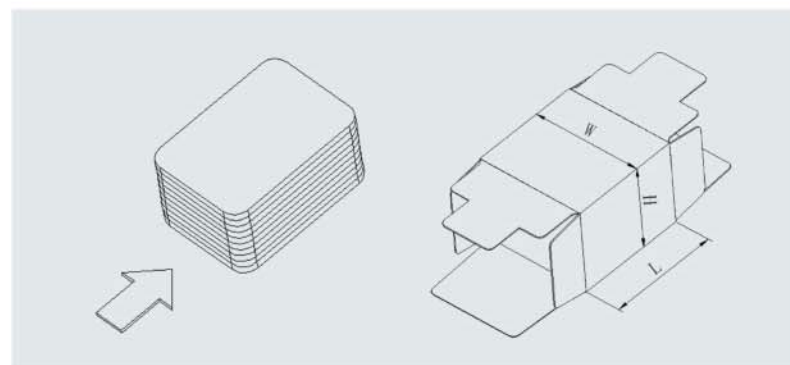

CAM-300

卫生巾包装机 Packaging of lady sanitary napkins



Features 产品特点

- 全伺服运动控制系统，通过电子轴进行的伺服电机管理
- Fully servo driven, Servo motor management by electronic CAM
- 力矩限制保护，机械性能更稳定
- Force restrict protection, stable running
- 模块化结构设计
- Modular structure design
- 在线自动制袋，色标定位
- Bag production Online, color sensor positioning
- 模具方式更换包装规格，更换简单方便
- Mould replacement specification, Easy operation
- 适应插片式和叠片式包装
- Can be used for insertion and Laminated



Main technical data 主要技术参数

Working speed	Up to 60 bags/min
生产速度	包装速度60包/分钟
Finished product rate	≥ 98%
成品率	≥ 98%
Number of pieces per row	6-30pieces/row
单排片数	6-30片/排
Finished bags dimensions: W x H x L	Min. 70x50x90 mm Max. 100x100x240 mm
包装尺寸: W x H x L	Min. 60x50x90 mm Max. 100x100x240 mm
Tube film bag (PE) thickness	50-70μ m
筒膜袋(PE)厚度	50-70μ m
General dimensions (LxWxH)	6000x1300x2350 mm
机台外观尺寸 (LxWxH)	6000x1300x2350 mm
Weight	2500KG
重量	2500KG
Electrical Power consumption	18KVA
功率	18KVA
Air Supply	0.65-0.85Mpa
供气压力	0.65-0.85Mpa
Standard process direction	Left-hand process , Right-hand process direction available upon request
标准生产流程方向	左手方向，右手方向可定制

